

SPECIFICATION
For
SWITCHING POWER SUPPLY

M/N: MPI-706H

Revision History

Version	Revise Date	Change Items
Rev. 01	Jul. 3. 2008	Update OVP description.
Rev. 02	Jul. 15. 2008	Mechanical drawing and description update.
Rev. 03	Mar. 28. 2011	Update the safety approved status.
Rev. 04	Oct. 28. 2011	Revised the specification of turn-on delay.
Rev. 05	Jan. 11. 2018	1. Changed form. 2. Added EN 55032.
Rev. 06	Jan. 15. 2019	Added output current to output field.



FEATURES

- ✓ 80W with 8.6CFM forced air- cooling, 60W convection cooling.
- ✓ 170 x 52 x 39 mm Slim size, ATX output.
- ✓ PG/PF Signal.
- ✓ +5V Stand by & Remote On/Off.
- ✓ MTBF>130,000 hr. MIL-217F.



Models & Ratings

Model Number	Wattage (Rated / Max)	Output Voltage		Min. Current	Rated Current	Max. Current (Note 1)
		V1	V2			
MPI-706H	60 W / 80 W	V1	+5 V	0.2 A	5.0 A	8.0 A
		V2	+12 V	0 A	1.5 A	4.0 A
		V3	-12 V	0 A	0.5 A	-
		V4	+3.3 V	0 A	4.0 A	6.0 A
		V5	+5Vsb	0 A	1.0 A	-

Total Output Power: maximum 80W with 8.6 CFM forced air-cooling and 60W convection cooling at 50°C ambient temperature.

Note:

1. The maximum total combined output power on the +3.3V and +5V rails is 40W.
2. While input voltage below 100V (90-99V), an accessory heat sink or the chassis of application (min. 440 cm², aluminum with 1.5mm thickness) is recommend to be placed at the bottom of the power supply itself.
3. Model no. coding:

MPI-706H - X
1

①	X=	blank
①	A	input with AC socket version

Summary

Characteristic	Minimum	Typical	Maximum	Units	Notes & Conditions
Input Range	90	115 / 230	264	VAC	Continuous input range.
Input Frequency	47		63	Hz	AC input.
Efficiency		75		%	Rated load, 115VAC. Varies with distribution of loads among output.
Operation Temperature	0		70	°C	Derate linearly above 50°C by 2.5% per °C to a maximum temperature of 70°C at 50% load.
Weight		208.4		g	
Dimensions	170.0 (L) x 52.0 (W) x 39.0 (H) mm, Tolerance +/- 0.4mm.				
EMC	EN 55022 / EN 55032, CISPR 22 & FCC Part 15, IEC 61000-4-2, IEC 61000-4-3, IEC 61000-4-4, IEC 61000-4-5, IEC 61000-4-6, IEC 61000-4-8, IEC 61000-4-11				
Safety Approvals	EN 60950-1: 2006+A11: 2009, UL 60950-1, 2nd Edition, 2007-03-27, CSA C22.2 No. 60950-1-07, 2nd Edition, 2007-03				

Input

Characteristic	Minimum	Typical	Maximum	Units	Notes & Conditions
Input Voltage	90	115 / 230	264	VAC	Continuous input range.
Input Frequency	47		63	Hz	AC input.
Input Current			2 / 1	A	Nominal AC Input Voltage (115VAC/230VAC), rated load.
Inrush Current			30 / 60	A	Nominal AC Input Voltage (115VAC/230VAC), one cycle at 25°C.
Input Protection	Non-user serviceable internally located AC input line fuse. Fuse : 5A / 250VAC * 1pcs				

Output

Characteristic	Minimum	Typical	Maximum	Units	Notes & Conditions
Output Voltage		+5 V		DC	
		+12 V			
		-12 V			
		+3.3 V			
		+5Vsb			
Output Current		5.0	8.0	A	
		1.5	4.0		
		0.5			
		4.0	6.0		
		1.0			
Initial Set Accuracy	5.08		5.13	VDC	The +5V output is set between 5.08V to 5.13V by variable resistor and all output at 60% rated load and the other outputs are checked to be within the accuracy range.
	11.4		12.6		
	-11.4		-12.6		
	3.1		3.5		
	4.8		5.2		
Minimum Load		0.2		A	At Output Voltage +5V At Output Voltage +12 V, -12 V, +3.3 V, +5Vsb
		0			
Start Up Delay			4	Sec	Time required for initial output voltage stabilization.
Hold Up Time	20			mS	Nominal AC Input Voltage (230VAC), rated load.
Line Regulation		±1.0 ^(V1) ±1.0 ^(V2) ±1.0 ^(V3) ±1.0 ^(V4) ±1.0 ^(V5)		%	Less than ±1% at rated load with ±10% changing in input voltage.
Load Regulation		±2.0 ^(V1) ±4.0 ^(V2) ±5.0 ^(V3) ±4.0 ^(V4) ±4.0 ^(V5)		%	Measured is done by changing the measured output loading +/-40% from 60% rated load, and keep other output is at 60% rated load.
Ripple & Noise		50 ^(V1) 120 ^(V2) 120 ^(V3) 50 ^(V4) 120 ^(V5)		mV	Measured at rated load by a 20MHz bandwidth limited oscilloscope and the each output is connected with a 10µF Electrolytic Capacitor and a 0.1µF Ceramic Capacitor.
Over Voltage Protection	For some reason the power supply fails to control itself, the build-in over voltage protection circuit will protect auto-recovery model and to prevent damaging external circuits. The trigger point is about 6.5-8.5V at +5V.				
Over Load Protection	Fully protected against output overload and short circuit. Automatic recovery upon of overload condition.				

General

Characteristic	Minimum	Typical	Maximum	Units	Notes & Conditions
Efficiency		75		%	Rated load, 115VAC. Varies with distribution of loads among output.
Isolation IP to OP	3000			VAC	
Switching Frequency		60		KHZ	
Power Good Signal	When power is turned on, the power good signal will go high 100ms to 500ms after all output DC voltages are within regulation limits.				
Power Fail Signal	The power fail signal will go low at least 1 mS before any of the output voltages fall below the regulation limits.				
Power On / Off	The power supply will be turned on when the power On/Off pin is connected to secondary GND.				

Environmental

Characteristic	Minimum	Typical	Maximum	Units	Notes & Conditions
Operating Temperature	0		70	°C	Derate linearly above 50°C by 2.5% per °C to a maximum temperature of 70°C at 50% load.
Storage Temperature	-40		+70	°C	
Relative Humidity	5		95	%RH	Non-condensing.
Cooling	8.6			CFM	Forced-cooled > 60W
Operating / Non - Operating Altitude		10000 / 40000		Feet	

EMC: Emissions

Phenomenon	Standard	Class	Notes & Conditions
Conducted	EN 55022 / EN 55032 CISPR 22 & FCC Part 15	B	
Radiated	EN 55022 / EN 55032 CISPR 22 & FCC Part 15	B	

EMC: Immunity

Phenomenon	Standard	Criteria	Notes & Conditions
ESD	IEC 61000-4-2	3	8KV air discharge, 6KV contact discharge
Radiated	IEC 61000-4-3	2	3V/m
EFT	IEC 61000-4-4	3	2KV Line & PE
Surges	IEC 61000-4-5	3	2KV
Conducted	IEC 61000-4-6	3	10V
Power Magnetic	IEC 61000-4-8	3	10A/m
Dips and Interruptions	IEC 61000-4-11	-	

Safety Approvals

Safety Agency	Safety Standard	Notes & Conditions
TUV	EN 60950-1: 2006+A11: 2009	Approved.
UL/cUL	UL 60950-1, 2nd Edition, 2007-03-27, CSA C22.2 No. 60950-1-07, 2nd Edition, 2007-03	Approved.

Mechanical Details

SIZE : 170.0(L) x 52.0(W) x 39.0(H)mm, Tolerance +/-0.4mm.

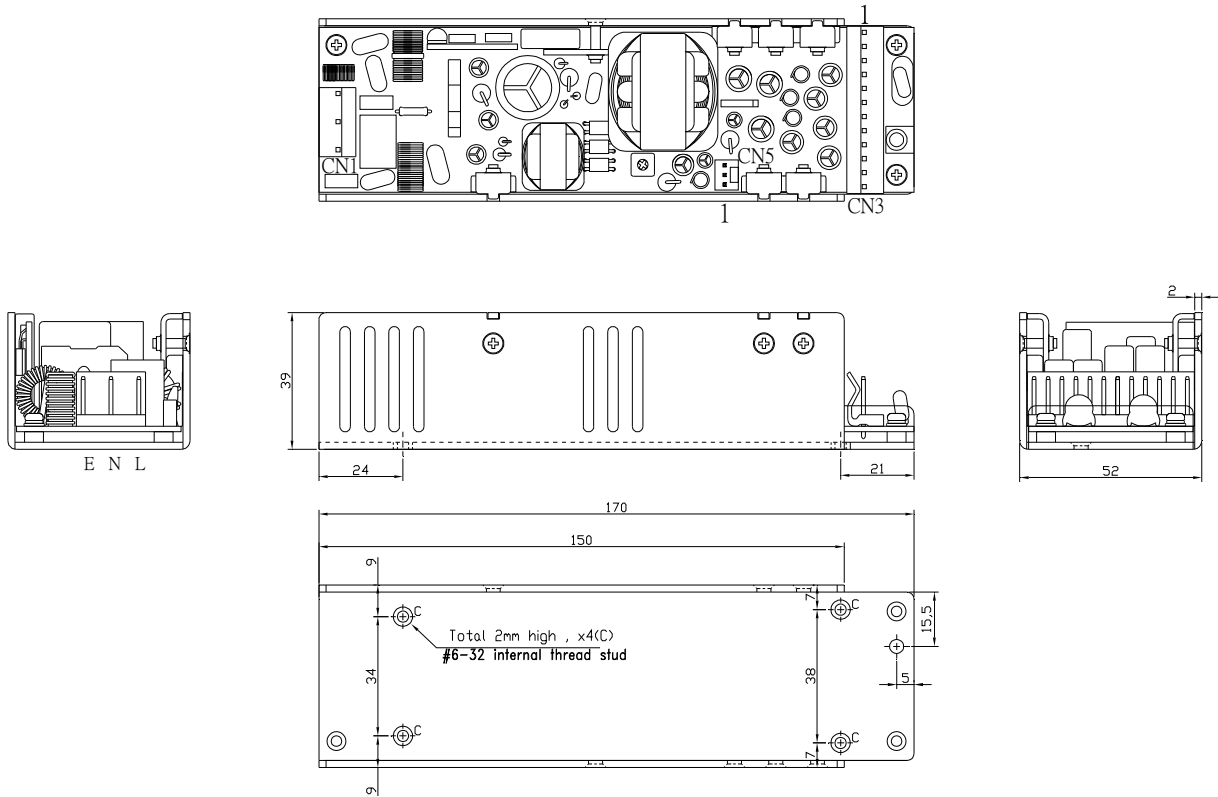

Measuring the screw protrusion first :

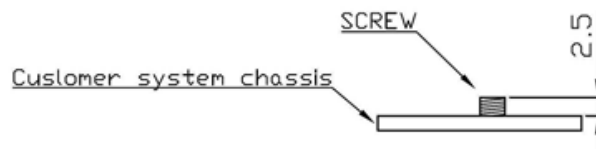

Parameter	Conditions/Description					
Dimension	170(L) x 52(W) x 39(H) mm, Tolerance +/- 0.4mm.					
Connector	CN1 --- AC input:	Molex 5273-05A withdraw 2 pins or equivalent.				
	CN3 --- DC output:	Molex 5273-12A or equivalent.				
	CN5 --- DC output:	Molex 5045-03A or equivalent.				
Pin Assignment	CN1	Pin	1. L	2. N	3. Earth	
	CN3	Pin	1. +3.3V	4. GND	7. +5V	10. PG/PF
			2. +3.3V	5. GND	8. +5V	11. +12V
			3. GND	6. GND	9. +5V	12. -12V
	CN5	Pin	1. +5Vsb	2. GND	3. PS on/off	

Thermal Considerations

In order to ensure safe operation of the PSU in the end-use equipment, the temperature of the components listed in the table below must not be exceeded.

Temperature should be monitored using J type thermocouples placed on the hottest part of the component (out of any direct air flow). See Mechanical Details for component locations.

Temperature Measurements at max. amb.	
Component	Max Temperature
T1	110°C
Q1	120°C
D5, D6	120°C
C2	105°C
C21	105°C